



SA-04

Wireless Emergency Pendant / Watch Transmitter

The SA-04 Panic Transmitter is a unique product due to its small size, light weight, usability, and ability to be used in both dry or wet conditions. The SA-04 is compatible with a variety of Rosslare's Home Security and Control Panels or with Universal Controls, within the same frequency: 418 / 433 / 868 MHz.

GENERAL DESCRIPTION

The SA-04 is a unique product due to its small size, light weight, usability, and ability to be used in both dry or wet conditions.

Inside the technology features a time hopping, slot based short range RF transmitter, which has a unique ID code of over 16 Million combinations, ensuring no duplicate units on the market.

The user can use an enrolled unit to operate and control emergency or automation tasks by using a Rosslare security and automation panel or universal receiver.

The waterproof unit can be worn both around the neck with the pendant attachment and metal chain, or on the wrist with the watch and comfort strap attachment.

SA-04 battery power can last for over 5 years with 100 presses a year, with a factory replaceable battery. It contains no user serviceable parts. The special waterproof enclosure can only be factory serviced for battery change.

Inside the unit features an optimized loop antenna, with a factory adjustable RF power to make the product meet international standards.

MAIN FEATURES

Multi Application Unit: The SA-04 can be used for PANIC and Emergency Transmissions with Rosslare's systems, or can be enrolled onto a universal control unit for automation uses.

Long Range Small Size: For such a small unit, the RF range and antenna design becomes a major problem SA-04as special antenna construction to get 50 to 100 m open space range with selected panels.

Unique Mechanicals: The water proof and damage proof enclosure allow for protection even when in the shower, bath, or pool, so the users don't need to be concerned about removing the unit. Leads to more comfort and utility.

Adjustable RF Power and Frequency: this allows us to produce units to meet almost any country.

High Capacity Lithium Battery: Powers the unit for up to over 5 years battery life. (100 Transmissions per day).

MECHANICALS

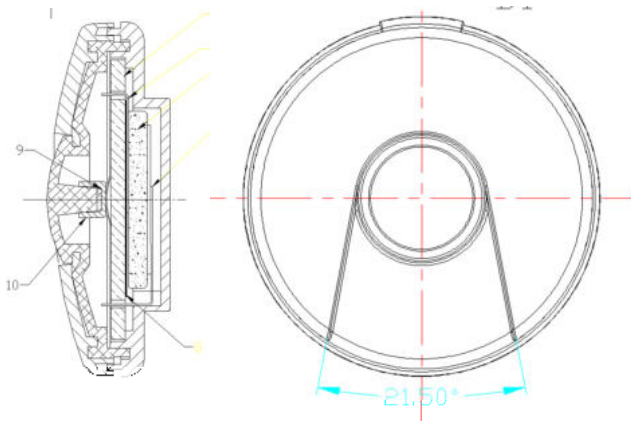

Model : SA-04

SPECIFICATIONS

Battery:	3-volt Lithium 250 mAh CR2023
	NOTE! Only factory replaceable cell, users should return the unit to Rosslare or an authorized distributor for service every 5 years.
Operating Temperature:	-10C to +50 C 14 F to + 122 F
Operating Humidity:	Water Proof to 1m deep.
Wrist Strap:	Comfort padded Velcro Strap provides a smooth surface contact with reliable hold.
Pendant:	Pendant adapter and stainless flexible metal chain, with latch for easy opening or closing.
Supervisor:	Not a supervised transmitter, means that the unit can be worn all the time in or out of the proximity of the system.
Wireless Frequency:	418 / 433 / 868 MHz
Current Consumption:	Standby – 0 uA Transmit - 16 mA
Size:	40 mm (Diameter) x 14 mm (Height)
Weight:	23 grams



SA-04

Wireless Emergency Pendant / Watch Transmitter

PRODUCT DETAILS

PIR

Glass Break

MAG

UNIVERSAL

Ionisation Smoke

Optical Smoke

Max Heat

Max Heat Rate of Rise

WIRELESS DETECTORS

As a a panic watch or pendant the SA-04 can be used to transmit an Emergency Signal to the Rosslare Wireless Security Control Panels SP-06V and Elderly Phone SP-03. Simply by pressing the button for over 2 seconds, the enrolled transmitter can signal an assortment of Voice Messaging, and Central Station Reporting. For universal applications the SA-04 can be fitted to work with many third party systems using the SA-38 (8-Channel Receiver) and SA-22 (2-Channel Receiver) units.

Multiple SA-04 can be digitally enrolled onto a control panels or universal receiver, allowing for multiple personal protection.

Users can call for help to private phone lines with 2-way voice listen-in and alarm pre-recorded voice messages

Users can alert a Central Monitoring Station which will relay the alarm to the relevant authorities;

Ambulance
Fire Extinguishing
Police Service

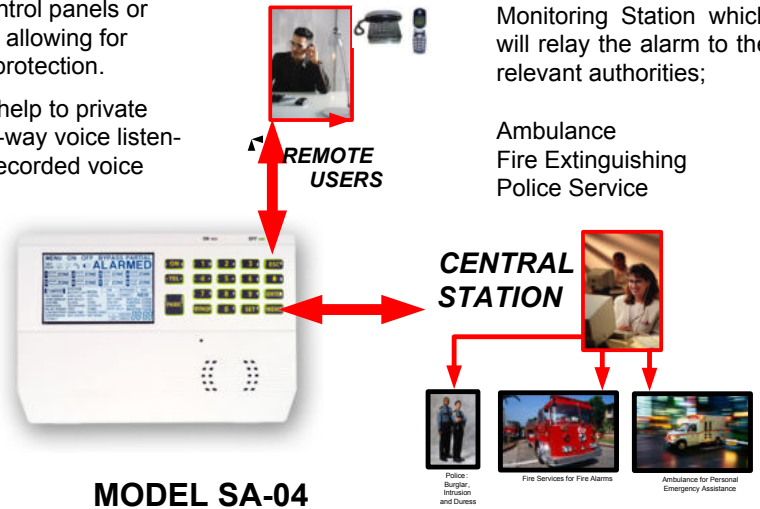

Model SA-04



The SA-04 unit is a waterproof device which can be worn in all conditions wet or dry.

MODEL SA-04



LOCAL USERS



LOCAL USERS



Teenagers

LOCAL USERS



Kids



Loved Elderly

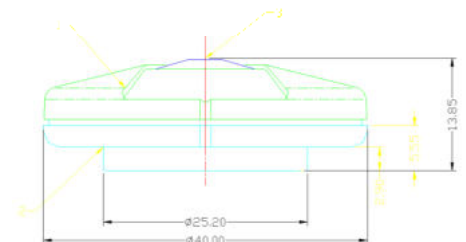

A Division of
Rosslare Enterprises Ltd.

ROSSLARE[®]
SECURITY PRODUCTS

www.rosslaresecurity.com