

# ECZ930F eZ.HD Series

1080p Full High Definition

True Day/Night Outdoor IR Bullet Camera

---

*User's Manual*



Copyright © EverFocus Electronics Corp.

Release Date: February 2016

## Precautions

1. **Do not install the camera near electric or magnetic fields.** Install the camera away from TV/radio transmitters, magnets, electric motors, transformers and audio speakers since the electromagnetic fields generated from these devices may distort the video image or otherwise interfere with camera operation.
2. **Never disassemble the camera beyond the recommendations in this manual nor introduce materials other than those recommended herein.** Improper disassembly or introduction of corrosive materials may result in equipment failure or other damage.
3. **Try to avoid facing the camera toward the sun.** In some circumstances, direct sunlight may cause permanent damage to the sensor and/or internal circuits, as well as creating unbalanced illumination beyond the capability of the camera to compensate.
4. **Keep the power cable away from water and other liquids and never touch the power cord with wet hands.** Touching a wet power cord with your hands or touching the power cord with wet hands may result in electric shock.
5. **Never install the camera in areas exposed to oil, gas or solvents.** Oil, gas or solvents may result in equipment failure, electric shock or, in extreme cases, fire.
6. **Cleaning.** For cameras with interchangeable lenses, do not touch the surface of the sensor directly with the hands. Use lens tissue or a cotton tipped applicator and ethanol to clean the sensor and the camera lens. Use a damp soft cloth to remove any dirt from the camera body. Please do not use complex solvents, corrosive or abrasive agents for cleaning of any part of the camera.
7. **Do not operate the camera beyond the specified temperature, humidity or power source ratings.** This camera is suitable for indoor operation only. Use the camera at temperatures within  $-10^{\circ}\text{C}\sim 50^{\circ}\text{C}$  ( $14^{\circ}\text{F}\sim 122^{\circ}\text{F}$ ) and humidity less than 80%; this device is not rated as submersible. The input power source is 12VDC. Be sure to connect the proper + / - polarity and voltage, as incorrect polarity or too high a voltage will likely cause the camera to fail, and such damage is not covered by the warranty.
8. **Mounting.** Use care in selecting a solid mounting surface which will support the weight of the camera plus any wind, snow, ice or other loading, and securely attach the camera to the mounting surface using screws and anchors which will properly support the camera. If necessary (e.g. when mounting to drop ceilings) use a safety wire to provide additional support for the camera.

# Safety Notice

## Federal Communication Commission Interference Statement

This equipment has been tested and found to comply with the limits for a Class A digital device, pursuant to Part 15 of the FCC Rules. These limits are designed to provide reasonable protection against harmful interference in a residential installation. This equipment generates uses and can radiate radio frequency energy and, if not installed and used in accordance with the instructions, may cause harmful interference to radio communications. However, there is no guarantee that interference will not occur in a particular installation. If this equipment does cause harmful interference to radio or television reception, which can be determined by turning the equipment off and on, the user is encouraged to try to correct the interference by one of the following measures:

- Reorient or relocate the receiving antenna.
- Increase the separation between the equipment and receiver.
- Connect the equipment into an outlet on a circuit different from that to which the receiver is connected.
- Consult the dealer or an experienced radio/TV technician for help.

**FCC Caution:** Any changes or modifications not expressly approved by the party responsible for compliance could void the user's authority to operate this equipment.

This device complies with Part 15 of the FCC Rules. Operation is subject to the following two conditions: (1) This device may not cause harmful interference, and (2) this device must accept any interference received, including interference that may cause undesired operation.



**ATTENTION!** This is a class A product which may cause radio interference in a domestic environment; in this case, the user may be urged to take adequate measures.<sup>4,5</sup>



This Product is RoHS compliant.<sup>4,5</sup>



WEEE<sup>4,5</sup>

Your EverFocus product is designed and manufactured with high quality materials and components which can be recycled and reused. This symbol means that electrical and electronic equipment, at their end-of-life, should be disposed of separately from your household waste. Please, dispose of this equipment at your local community waste collection/recycling centre. In the European Union there are separate collection systems for used electrical and electronic product.<sup>4,5</sup>  
Please, help us to conserve the environment we live in!

# Contents

|  |           |
|--|-----------|
| <b>1. Introduction.....</b>                  | <b>5</b>  |
| 1.1 Packing List .....                       | 5         |
| 1.2 Features .....                           | 5         |
| <b>2. Cable Description.....</b>             | <b>6</b>  |
| <b>3. Installation .....</b>                 | <b>7</b>  |
| 3.1 Installation and Adjustment .....        | 7         |
| <b>4. Configuration in the OSD Menu.....</b> | <b>10</b> |
| <b>5. Specifications.....</b>                | <b>14</b> |

## 1. Introduction

The EverFocus eZ.HD Series ECZ930F provides incredible performance in bright light or low light, and the resolution listed in the specification from the actual camera you install. To take full advantage of the amazing resolution available from this advanced imaging technology, the EverFocus eZ.HD Series ECZ930F uses a fixed lens together with 1/2.9" SONY 2.24M pixels CMOS to deliver 1080p high resolution, 30 LEDs with range of 15m/50ft., together with a useable native low light sensitivity of 0 lux without using digital slow shutter. The camera truly provides optimized images without compromising 1080p high resolution. The Digital Wide Dynamic Range function provides clear color images in the most challenging of bright or unbalanced lighting conditions. The true day/night IR enhances images in low light environments with guaranteed ZERO ghosting. The ECZ930F camera is equipped with an IP66 weather resistant housing and a 3-axis rotation mechanical design that delivers wall or ceiling mounting flexibility. The camera also features 3.6mm/6mm lens which provides astounding image quality, a full suite of OSD Menu and DSP functions controllable at the camera (3DNR to save DVR HDD space, privacy masking, mirroring, and much more). This is the camera that you have been waiting for to create analog CCTV systems that produce astounding image clarity in a wide range of outdoor applications at the widest range of light levels. The ECZ930F supports both NTSC and PAL scanning systems, which can be switched via OSD.

### 1.1 Packing List

- Camera Body x 1
- User Manual x 1
- Screw x 3
- Warning Paper x 1
- Hexagon Wrench x1
- Template Plate x1
- Plastic Anchor x 3

### 1.2 Features

- 1080p full HD with high flexibility and performance for astounding image
- 1/2.9" SONY 2.24M pixels CMOS sensor, delivering amazing high sensitivity
- Astounding image quality from the 3.6mm/6mm
- Extended IR range of up to 15M/50ft. with 30 LEDs (depending on scene IR reflectivity)
- D-WDR to improve the visibility under high contrast scene
- 3D Noise Reduction ensures less blurry moving subjects, vivid and high SN ratio images even under low light environments
- Supports 1080p, 720p & 960H analog signal output, which can be easily switched using OSD Joystick
- Internal wire system with anti-cut bracket
- Supports ceiling mount and wall mount
- eZ.Controller function: Control camera OSD settings and PTZ operation directly from DVR end

## 2. Cable Description



| No. | Name                          | Descriptions  |
|-----|-------------------------------|---|
| 1   | <b>Power Cable</b>            | Connects to a 12VDC power source.   |
| 2   | <b>Video Output</b>           | 1080p, 720p and 960H output, using a 75 Ohm BNC-type coaxial cable.                               |
| 3   | <b>DC Power Pigtail Cable</b> | Optional power pigtail cable. The red wire is positive (+); while the black wire is negative (-). |

## 3. Installation

### 3.1 Installation and Adjustment

1. For Ceiling Mount / Wall Mount users: Stick the **Template Plate** on the position where you want to attach the camera.

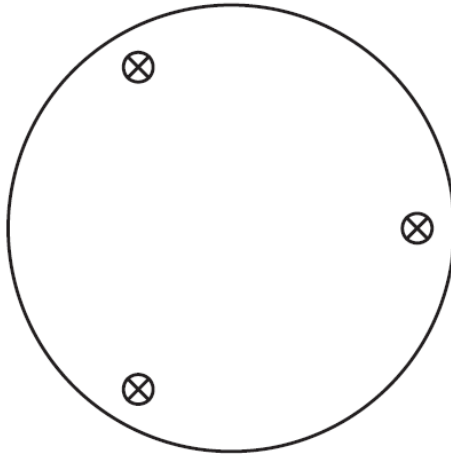

2. Drill three holes according to the supplied **Template Plate**, and insert the supplied **Plastic Anchors** into the holes.

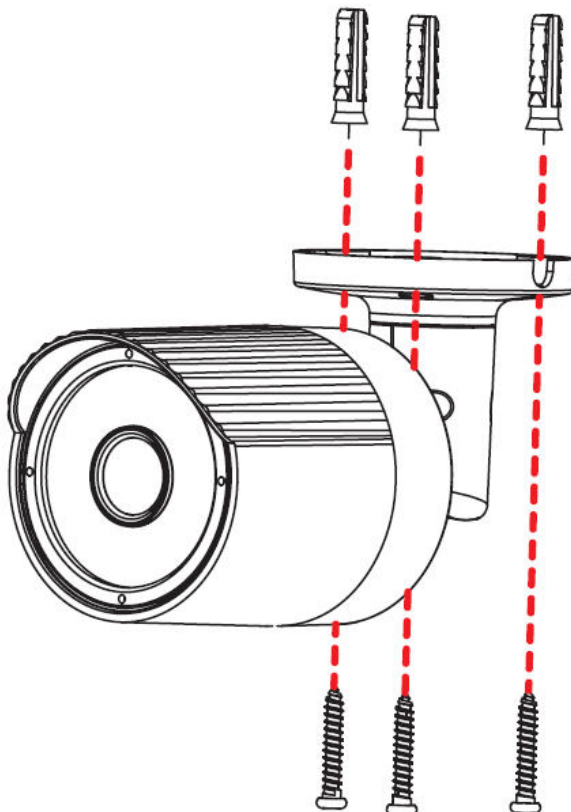

3. Connect the camera to an AHD DVR with the 12VDC power source using the supplied **DC Power Pigtail Cable** or a power adapter.

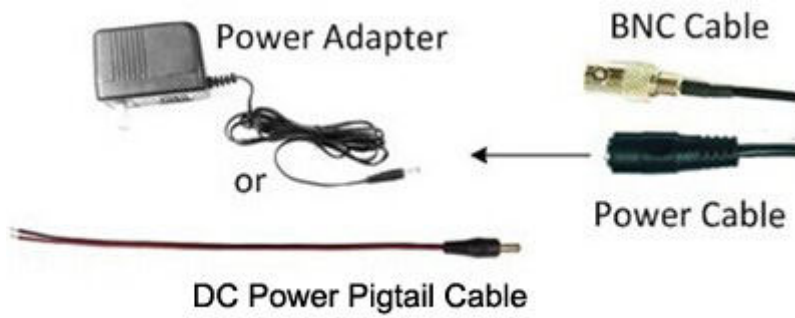

4. Adjust camera angles by tilting or rotating the camera. Then fasten the bracket with the **Hexagon Wrench** (Note: The bracket base can be rotated by 360°, the housing body also can be rotated by 360° and tilted by 90°).

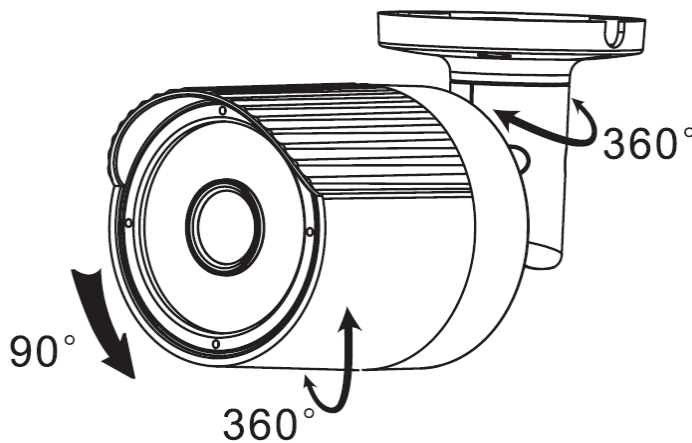

5. Configure camera settings by using the OSD Menu Joystick.

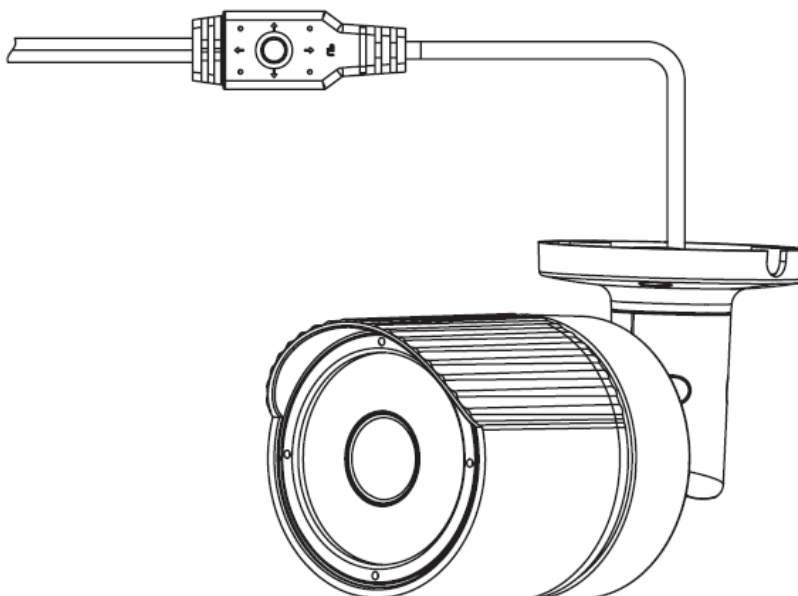



**OSD indication as shown in the figure:**

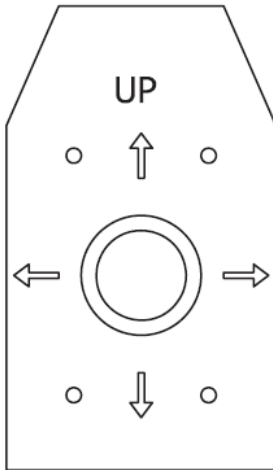

- Push the Joystick up / down to select among menu items.
- Push the Joystick left / right to adjust the level of the selected item.
- Press the Joystick to enter the submenu or exit the OSD Setup Menu.

**Note: The function button is using to control direction, and also to switch video format and video output. Please follow the detailed instruction as below to switch the camera to:**

- ✧ Switch between 1080p and 720p (Default, 1080p): Press Upward for 5 Seconds
- ✧ Switch from HD (1080p / 720p) to 960H: Press Left for 5 Seconds
- ✧ Switch from 960H to HD (1080p / 720p): Press Right for 5 Seconds
- ✧ Switch between NTSC and PAL: Press Downward for 5 Seconds

## 4. Configuration in the OSD Menu

You can use the Joystick on the bottom housing of the camera to configure camera settings in the OSD menu. The OSD menu structure is as below:

| No.     | Main          | Sub Menu   | Sub Menu / Function  |                            |   |  |
|---------|---------------|------------|--|----------------------------|---|--|
| 1       | Lens          | Manual     |  |                            |   |  |
| 2       | Exposure      | Shutter    | NTSC: 1/30, 1/60, FLK, 1/240, 1/480, 1/1000, 1/2000, 1/5000, 1/10000, 1/50000, X2, X4, X6, X8, X10, X15, X20, X25, X30, Auto |                            |   |  |
|         |               |            | PAL: 1/25, 1/50, FLK, 1/200, 1/400, 1/1000, 1/2000, 1/5000, 1/10000, 1/50000, X2, X4, X6, X8, X10, X15, X20, X25, X30, Auto  |                            |   |  |
|         |               | AGC        | 0 – 15   |                            |   |  |
|         |               | Sens-up    | Off  |                            |   |  |
|         |               |            | Auto   | Sens-up                    | X2, X4, X6, X8, X10, X15, X20, X25, X30 |  |
|         |               | Brightness | 1-100(40)  |                            |   |  |
|         |               | D-WDR      | Off  |                            |   |  |
|         |               |            | On   | Level                      | 0-8                                     |  |
|         |               |            | Auto   |                            |   |  |
|         |               | Defog      | Off  |                            |   |  |
| Auto    | Pos/Size      |            | Position, Size, ↑, ↓, →, ←   |                            |   |  |
|         | Gradation     |            | 0-2  |                            |   |  |
| Default |               |            |  |                            |   |  |
| 3       | Backlight     | Off        |  |                            |   |  |
|         |               | BLC        | Level  | Middle, High, Low          |   |  |
|         |               |            | Area   | Position, Size, ↑, ↓, →, ← |   |  |
|         |               |            | Default  |                            |   |  |
|         |               | HSBLC      | Select   | Area1, Area2, Area3, Area4 |   |  |
|         |               |            | Display  | Off                        |   |  |
|         |               |            |  | On                         | Position, Size, ↑, ↓, →, ←              |  |
|         |               |            | Black Mask   | On/Off                     |   |  |
|         |               |            | Level  | 0-100                      |   |  |
|         |               |            | Model  | All Day                    |   |  |
| Night   | AGC Level     | 0-255      |  |                            |   |  |
| Default |               |            |  |                            |   |  |
| 4       | White Balance | ATW        |  |                            |   |  |
|         |               | AWC→SET    |  |                            |   |  |

|        |                            |                          |                     |   |                         |      |                            |
|--------|----------------------------|--------------------------|---------------------|---|-------------------------|------|----------------------------|
|        |                            | Indoor                   |                     |   |                         |      |                            |
|        |                            | Outdoor                  |                     |   |                         |      |                            |
|        |                            | Manual                   | Blue                | 1-500   |                         |      |                            |
|        |                            |                          | Red                 | 0-100   |                         |      |                            |
| AWB    |                            |                          |                     |   |                         |      |                            |
| 5      | Day & Night                | Ext                      | D→N(Delay)          |   | 0-60                    |      |                            |
|        |                            |                          | N→D(Delay)          |   | 0-60                    |      |                            |
|        |                            | Auto                     | D→N(AGC)            |   | 1-255                   |      |                            |
|        |                            |                          | D→N(Delay)          |   | 0-60                    |      |                            |
|        |                            |                          | N→D(AGC)            |   | 1-255                   |      |                            |
|        |                            |                          | N→D(Delay)          |   | 0-60                    |      |                            |
|        |                            | Color                    |                     |   |                         |      |                            |
|        |                            | B/W                      | Burst               |   | Off/On                  |      |                            |
|        |                            |                          | IR Smart            | Off   |                         |      |                            |
|        |                            |                          |                     | On  | Level                   | 0-15 |                            |
| Area   | Position, Size, ↑, ↓, →, ← |                          |                     |   |                         |      |                            |
| IR PWM |                            | 0-100                    |                     |   |                         |      |                            |
| 6      | NR                         | 2DNR                     | Middle/Low/Off/High |   |                         |      |                            |
|        |                            | 3DNR                     | Middle/Low/Off/High |   |                         |      |                            |
| 7      | Special                    | Cam Title                | Off                 |   |                         |      |                            |
|        |                            |                          | On                  | 0123456789ABCDEFGHIJKLMN OPQRSTUVWXYZ▶→<br>← ↑ ↓ () ^ _ █ /=&:~., |                         |      |                            |
|        |                            | D-effect                 | Freeze              | Off/On  |                         |      |                            |
|        |                            |                          | Mirror              | Off, Mirror, V-flip, Rotate                                       |                         |      |                            |
|        |                            |                          | Neg. Image          | Off/On  |                         |      |                            |
|        |                            | Motion                   | On                  | Off   |                         |      |                            |
|        |                            |                          |                     | Select  | Area1,Area2,Area3,Area4 |      |                            |
|        |                            |                          |                     |   | Display                 | On   | Position, Size, ↑, ↓, →, ← |
|        |                            |                          |                     | Off   |                         |      |                            |
|        |                            |                          |                     | Sensitivity   | 0-100                   |      |                            |
| Color  | Green, Blue, White, Red    |                          |                     |   |                         |      |                            |
| Trans  | 1.00,0.75,0.50, 0.25       |                          |                     |   |                         |      |                            |
| Alarm  | View Type                  | Off, Block, Outline, All |                     |   |                         |      |                            |
|        | OSD View                   | On/Off                   |                     |   |                         |      |                            |
|        | Alarm Out                  | On/Off                   |                     |   |                         |      |                            |

|  |            |           |   |  |  |  |
|--|------------|-----------|---|--|--|--|
|  |            |           |   | Time   | 1-15                                   |  |
|  |            |           | Default   |  |  |  |
|  | Privacy    | Off       |   |  |  |  |
|  |            | On        | Select  | Area1,Area2,Area3,Area4                      |  |  |
|  |            |           | Display   | Off  |  |  |
|  |            |           |   | Color  | Position, Size, ↑, ↓, →, ←             |  |
|  |            |           |   | Mosaic                                       | Position, Size, ↑, ↓, →, ←             |  |
|  |            |           |   | Inv  | Position, Size, ↑, ↓, →, ←             |  |
|  |            |           | Color   | White, Black, Red, Blue, CYAN, Yellow, Green |  |  |
|  |            |           | Trans   | 1.00,0.75,0.50, 0.25                         |  |  |
|  |            |           | Default   |  |  |  |
|  |            | Language  | ENG/CHN1/CHN2/GER/FRA/ITA/SPA/POL/RUS/POR/NED/TUR |  |  |  |
|  | Defect     | Live DPC  | Off   |  |  |  |
|  |            |           | On  | AGC level                                    | 0-255                                  |  |
|  |            |           |   | Level  | 0-100                                  |  |
|  |            | White DPC | On  | Off  |  |  |
|  |            |           |   | Pos/Size                                     | Position, Size, ↑, ↓, →, ←             |  |
|  |            |           |   | Start  | Close the iris then press              |  |
|  |            |           |   | DPC View                                     | Off/On                                 |  |
|  |            |           |   | Level  | 0-60                                   |  |
|  |            |           |   | AGC  | 0-14                                   |  |
|  |            |           |   | Sens-up                                      | x2, x4, x6, x8,x10, x15, x20, x25, x30 |  |
|  |            | Black DPC | On  | Off  |  |  |
|  |            |           |   | Pos/Siz                                      | Position, Size, ↑, ↓, →, ←             |  |
|  |            |           |   | Start  | Press Enter                            |  |
|  |            |           |   | DPC View                                     | Off/On                                 |  |
|  |            |           |   | Level  | 0-255                                  |  |
|  |            | RS485     | CAM ID  | 0-255  |  |  |
|  | ID Display |           | Off/On  |  |  |  |

|   |        |                            |           |                             |  |  |  |
|---|--------|----------------------------|-----------|-----------------------------|--|--|--|
|   |        |                            | Baud Rate | 2400,4800,9600,19200 ,38400 |  |  |  |
| 8 | Adjust | Sharpness                  | Off       |                             |  |  |  |
|   |        |                            | Auto      | Level                       | 0-10   |  |  |
|   |        |                            |           | Start AGC                   | 0-255  |  |  |
|   |        |                            |           | End AGC                     | 0-255  |  |  |
|   |        | Monitor                    | CRT       | Black Level                 | 0-60   |  |  |
|   |        |                            |           | Blue Gain                   | 0-100  |  |  |
|   |        |                            |           | Red Gain                    | 0-255  |  |  |
|   |        |                            | LCD       | Gamma                       | User,0.45,0.50,0.55,0.60,0.65,0.70,0.75,0.80,0.85,0.90,0.95,1.00 |  |  |
|   |        |                            |           | Blue Gain                   | 0-100  |  |  |
|   |        |                            |           | Red Gain                    | 0-100  |  |  |
|   |        | LSC                        | Off/On    |                             |  |  |  |
|   |        | Video. Out                 | PAL/NTSC  |                             |  |  |  |
| 9 | Exit   | Save& END /Reset/Not Saved |           |                             |  |  |  |

## 5. Specifications

|                              |  |
|------------------------------|--|
| <b>P/N</b>                   | ECZ930F  |
| <b>Pickup Device</b>         | 1/2.9" SONY 2.24M pixels CMOS                        |
| <b>Video Format</b>          | NTSC and PAL( can be switched via OSD)               |
| <b>Effective Pixels</b>      | 1920 (H)*1080 (V)                                    |
| <b>Scanning System</b>       | Progressive Scan                                     |
| <b>Sensitivity</b>           | 0 lux with IR on                                     |
| <b>S/N Ratio</b>             | Over 48 dB (AGC OFF)                                 |
| <b>Electronic Shutter</b>    | AUTO, Manual (X30~1/ 50000), FLK                     |
| <b>Video Output</b>          | BNC 1.0Vp-p 75Ω                                      |
| <b>Gamma Correction</b>      | 0.45   |
| <b>Lens Type</b>             | 3.6mm/6mm fixed lens                                 |
| <b>BLC</b>                   | OFF/BLC/HS BLC Selectable                            |
| <b>AGC</b>                   | 0~15 Levels  |
| <b>White Balance</b>         | ATW/AWC-SET/INDOOR/OUTDOOR/MANUAL/AWB                |
| <b>Sync Mode</b>             | Internal   |
| <b>Day/Night</b>             | Ext, Auto, Color, B/W                                |
| <b>IR LED</b>                | 30 Units   |
| <b>IR Distance</b>           | Up to 15m/50ft. (depending on scene IR reflectivity) |
| <b>OSD Languages</b>         | 12-Language  |
| <b>DNR</b>                   | 2DNR/3DNR, Off                                       |
| <b>DEFOG</b>                 | Off/Auto   |
| <b>D-WDR</b>                 | On/Off   |
| <b>Sens-up</b>               | Off/Auto(x2~x30)                                     |
| <b>Mirror</b>                | Off, Mirror, V-flip, Rotate                          |
| <b>Motion Detection</b>      | On/Off for 4 selectable zones                        |
| <b>Privacy Mask</b>          | On/Off for 4 selectable zones                        |
| <b>Environmental</b>         | IP66 Weather Resistant                               |
| <b>Power Source</b>          | 12VDC  |
| <b>Power Source</b>          | 3w max.  |
| <b>Operating Temperature</b> | -10°C~50°C / 14°F~122°F                              |
| <b>Humidity</b>              | Less than 80%  |
| <b>Dimensions</b>            | 166.7 x 66 x 66mm / 6.56" x 2.60" x 2.60"            |
| <b>Weight</b>                | 400g/0.88lbs   |
| <b>Certifications</b>        | CE/FCC/ RoHS   |

Specifications and designs are subject to change for improving the functionality of this product without notice.

## EverFocus Electronics Corp.

### EverFocus Taiwan:

12F-1, No.79, Sec. 1, Shin-Tai Wu Road,  
Hsi-Chih, New Taipei City, Taiwan  
TEL: +886 2 2698 2334  
FAX: +886 2 2698 3943  
[www.everfocus.com.tw](http://www.everfocus.com.tw)  
[marketing@everfocus.com.tw](mailto:marketing@everfocus.com.tw)

### EverFocus China - Beijing:

Room 609, Technology Trade Building,  
Shangdi Information Industry Base,  
Haidian District, Beijing 100085, China  
TEL: +86 10 6297 3336~39  
FAX: +86 10 6297 1423  
[www.everfocus.com.cn](http://www.everfocus.com.cn)  
[marketing@everfocus.com.cn](mailto:marketing@everfocus.com.cn)

### EverFocus USA - California:

1801 Highland Avenue, Unit A, Duarte, CA 91010,  
USA  
TEL: +1 626 844 8888  
FAX: +1 626 844 8838  
[www.everfocus.com](http://www.everfocus.com)  
[sales@everfocus.com](mailto:sales@everfocus.com)

### EverFocus Europe - Germany:

Albert-Einstein-Strasse 1, D-46446  
Emmerich, Germany  
TEL: +49 2822 93940  
FAX: +49 2822 939495  
[www.everfocus.de](http://www.everfocus.de)  
[sales@everfocus.de](mailto:sales@everfocus.de)

### EverFocus China - Shenzhen:

4F, No. 2, D4 Building, Wan Yelong  
Industrial Park, Tangtou Road, Shiyan,  
Baoan, Shenzhen, Guangdong 518101, China  
TEL: +86 755 2765 1313  
FAX: +86 755 2765 0337  
[www.everfocus.com.cn](http://www.everfocus.com.cn)  
[marketing@everfocus.com.cn](mailto:marketing@everfocus.com.cn)

### EverFocus Japan:

3F Kuramochi, BuildingII 2-2-3 Koto-Bashi,  
Sumida-Ku Tokyo, 130-0022, Japan  
TEL: +81 3 5625 8188  
FAX: +81 3 5625 8189  
[www.everfocus.co.jp](http://www.everfocus.co.jp)  
[info@everfocus.co.jp](mailto:info@everfocus.co.jp)



Your EverFocus product is designed and manufactured with high quality materials and components which can be recycled and reused. This symbol means that electrical and electronic equipment, at their end-of-life, should be disposed of separately from your household waste. Please, dispose of this equipment at your local community waste collection/recycling centre. In the European Union there are separate collection systems for used electrical and electronic product. Please, help us to conserve the environment we live in!

Ihr EverFocus Produkt wurde entwickelt und hergestellt mit qualitativ hochwertigen Materialien und Komponenten, die recycelt und wieder verwendet werden können. Dieses Symbol bedeutet, dass elektrische und elektronische Geräte am Ende ihrer Nutzungsdauer vom Hausmüll getrennt entsorgt werden sollen. Bitte entsorgen Sie dieses Gerät bei Ihrer örtlichen kommunalen Sammelstelle oder im Recycling Centre. Helfen Sie uns bitte, die Umwelt zu erhalten, in der wir leben!



**EverFocus**