

AY-Bx660 Family

Full Fingerprint Match-on-Card Readers

Installation Manual

Models:

AY-B1660

AY-B2660



AY-B1660



AY-B2660

ROSSLARE
SECURITY PRODUCTS

Copyright © 2013 by Rosslare. All rights reserved.

This manual and the information contained herein are proprietary to ROSSLARE ENTERPRISES LIMITED and/or its related companies and/or subsidiaries' (hereafter: "ROSSLARE"). Only ROSSLARE and its customers have the right to use the information.

No part of this manual may be re-produced or transmitted in any form or by any means, electronic or mechanical, for any purpose, without the express written permission of ROSSLARE.

ROSSLARE owns patents and patent applications, trademarks, copyrights, or other intellectual property rights covering the subject matter in this manual.

TEXTS, IMAGES, AND ILLUSTRATIONS INCLUDING THEIR ARRANGEMENT IN THIS DOCUMENT ARE SUBJECT TO THE PROTECTION OF COPYRIGHT LAWS AND OTHER LEGAL RIGHTS WORLDWIDE. THEIR USE, REPRODUCTION, AND TRANSMITTAL TO THIRD PARTIES WITHOUT EXPRESS WRITTEN PERMISSION MAY RESULT IN LEGAL PROCEEDINGS.

The furnishing of this manual to any party does not give that party or any third party any license to these patents, trademarks, copyrights or other intellectual property rights, except as expressly provided in any written agreement of ROSSLARE.

ROSSLARE reserves the right to revise and change this document at any time, without being obliged to announce such revisions or changes beforehand or after the fact.

Table of Contents

1. Introduction	7
1.1 Features.....	7
2. Technical Specifications	8
3. Installation	10
3.1 Mounting Instructions	10
3.2 Wiring Instructions	12
4. Configuring the Reader	14
4.1 Configuration Procedure	14
5. Testing the Reader	16
6. Modes of Operation	17
6.1 Boot Mode	17
6.2 Configuration Mode.....	17
6.3 Standby Mode	18
6.4 Read Mode.....	18
6.4.1 Valid Card/Fingerprint Read	18
6.4.2 Invalid Card/Fingerprint Read.....	19
6.5 Lockout Mode	20
6.6 Fingerprint Matching Override Mode.....	20
6.7 Duress Mode	20
A. Limited Warranty	21

List of Figures

Figure 1: AY-B1660 – Mounting Dimensions.....	10
Figure 2: AY-B2660 – Mounting Dimensions.....	11
Figure 3: Removing the Top Cover	12

List of Tables

Table 1: Wiring the Reader to the Controller13

Notice and Disclaimer

This manual's sole purpose is to assist installers and/or users in the safe and efficient installation and usage of the system and/or product, and/or software described herein.

BEFORE ATTEMPTING TO INSTALL AND/OR USE THE SYSTEM, THE INSTALLER AND THE USER MUST READ THIS MANUAL AND BECOME FAMILIAR WITH ALL SAFETY REQUIREMENTS AND OPERATING PROCEDURES.

- The system must not be used for purposes other than those for which it was designed.
- The use of the software associated with the system and/or product, if applicable, is subject to the terms of the license provided as part of the purchase documents.
- ROSSLARE exclusive warranty and liability is limited to the warranty and liability statement provided in an appendix at the end of this document.
- This manual describes the maximum configuration of the system with the maximum number of functions, including future options. Therefore, not all functions described in this manual may be available in the specific system and/or product configuration you purchased.
- Incorrect operation or installation, or failure of the user to effectively maintain the system, relieves the manufacturer (and seller) from all or any responsibility for consequent noncompliance, damage, or injury.
- The text, images and graphics contained in the manual are for the purpose of illustration and reference only.
- All data contained herein subject to change without prior notice.
- In no event shall manufacturer be liable for any special, direct, indirect, incidental, consequential, exemplary or punitive damages (including, without limitation, any and all damages from business interruption, loss of profits or revenue, cost of capital or loss of use of any property or capital or injury).
- All graphics in this manual are for reference only, some deviation between the image(s) and the actual product may occur.
- All wiring diagrams are intended for reference only, the photograph or graphic of the PCB(s) are intended for clearer illustration and understanding of the product and may differ from the actual PCB(s).

1. Introduction

The MIFARE® Smart Card Fingerprint Capacitive Sensor Match-On-Card (MOC) readers, utilizing MOC technology developed by Rosslare, are biometric fingerprint readers that are used with access control systems.

The AY-Bx660 series of readers use a full finger capacitive type biometric sensor to check for verification between fingerprint data and a biometric template stored in the MIFARE card. When verification is confirmed, the reader then transmits the Card ID or any ID stored in Sector 0 or 15 for 1K cards, or Sector 0 or 23 and up for 4K cards with dual templates, to the access controller, which compares the card ID to data stored in the database and determines access granting.

The readers are compatible with most access control hardware, including the following hardware manufactured by Rosslare Security Products: AC-015, AC-115, AC-020, AC-215, AC-225, AC-425, AC-525, and ExpansE™.

1.1 Features

The AY-Bx660 series of readers include the following features:

- Two different designs to accommodate customer requirements and preferences
- Support back tamper sensor and tamper output signal
- Support lockout feature for increased security
- Compatible with MIFARE (ISO 14443A) 1K and 4K cards
- MIFARE card followed by reading fingerprint
- Reads up to 2 fingerprint templates stored on the card
- Programmable data transmission formats
- Programmable LED control and buzzer control inputs

2. Technical Specifications

General Characteristics

Output Formats	<ul style="list-style-type: none">• Wiegand 26-Bit (default)• Wiegand 26-Bit with Facility Code• Wiegand 32-Bit Reversed• Clock & Data• Wiegand 32-Bit• Wiegand 34-Bit• Wiegand 40-Bit
Read Range (max)	4 cm (1.6 in.)

Electrical Characteristics

Power Supply Type	Linear type (recommended)
Input Voltage	5 to 16 VDC
Absolute Maximum (non-operating)	18 VDC
Maximum Input Current	Standby: 60 mA @ 12 VDC Read: 135 mA @ 12 VDC
Tamper Output	Open collector, active low, max. sink current 32 mA
Maximum Controller Cable Distance	150 m (500 ft.) (using 18AWG shielded cable)
Frequency	13.56 MHz
Card Compatibility	MIFARE ISO14443A-3 standard

Environmental Characteristics

Operating Temp. Range	-25°C to 60°C (-13°F to 140°F)
Storage Temp. Range	-40°C to 85°C (-40°F to 140°F)
Operating Humidity	30 to 85% (non-condensing)

Physical Characteristics

Dimensions (H x W x D)	AY-B1660: 100 x 54 x 42 mm (3.94 x 2.13 x 1.65 in.)
	AY-B2660: 102 x 54 x 32 mm (4.02 x 2.13 x 1.26 in.)
Weight	AY-B1660: 79 g (2.79 oz)
	AY-B2660: 156 g (5.50 oz)

3. Installation

3.1 Mounting Instructions

Prior to starting, select the location where the reader unit is to be mounted. Use the supplied drilling template to assist in locating and drilling the appropriate holes (Figure 1 and Figure 2).

Figure 1: AY-B1660 – Mounting Dimensions

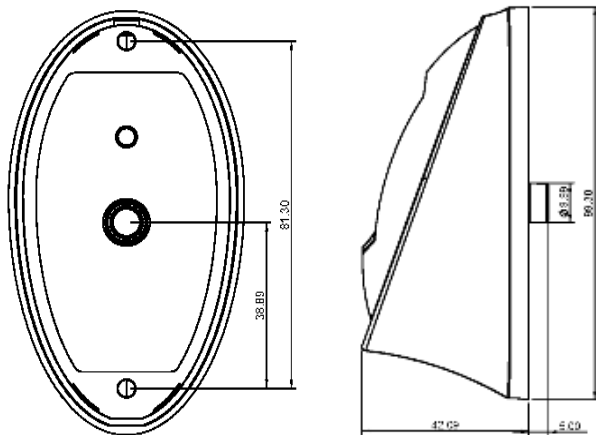
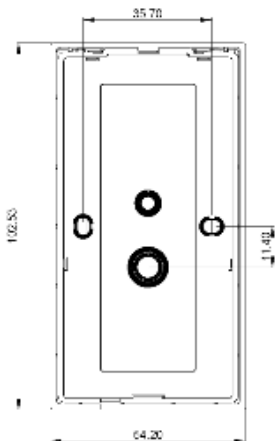

Figure 2: AY-B2660 – Mounting Dimensions



Be sure to protect the fingerprint sensor when the reader is mounted outside.

To mount the reader:

1. Determine an approximate surface location for the reader.
2. Peel off the back of the self-adhesive mounting label template and place it on the required mounting location.
3. Using the template as a guide, drill two holes (of the size indicated on the template) on the surface to mount the reader.
4. Insert a suitable wall plug into each hole.
5. Drill a 10-mm ($\frac{7}{16}$ ") hole for the cable. If the surface is metal, place a grommet or electrical tape around the edge of the hole.
6. Unscrew and remove the case security screw at the bottom using the security hex key.

- Carefully remove the snap-off front cover of the reader to reveal two screw holes.

Figure 3: Removing the Top Cover

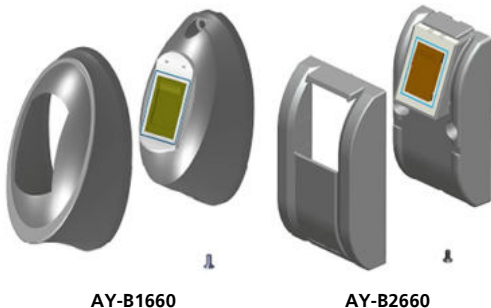

- Route the interface cable from the reader to the controller (see Section 3.2).



The reader can also be mounted using strong epoxy glue. After application, firmly hold the reader in place until the glue dries.

- Carefully re-attach the snap-off front cover of the reader and secure the case security screw at the bottom using the security hex key.

3.2 Wiring Instructions

The AY-Bx660 readers are supplied with a 7-wire, 46-cm (18") cable.

To connect the reader to the controller:

- Prepare the unit's cable by cutting the cable jacket back 3.2 cm (1¼") and stripping the wire 1.3 cm (½").
- Prepare the controller cable by cutting the cable jacket back 3.2 cm (1¼") and stripping the wire 1.3 cm (½").
- Splice the reader pigtail wires to the corresponding controller wires (see Table 1) and cover each connection.

Table 1: Wiring the Reader to the Controller

Color	Wiring
Black/ Shield	Ground
Red	Vin
Green	Data 0
White	Data 1
Brown	LED control
Orange	Buzzer control
Purple	Tamper

4. If the tamper output is being utilized, connect the purple wire to the correct input on the controller.
5. Trim and cover all conductors that are not used.



- The individual wires extending from the reader are color-coded according to the required Wiegand standard.
- When using a separate power supply for the reader, this supply and the controller's power supply must have a common ground. A linear power supply is recommended.
- Attach the cable shield wire on the reader to an earth ground (best), or to a signal ground connection at the panel or power supply end of the cable. This configuration is best for shielding the reader cable from external interference.

4. Configuring the Reader

To provide the highest level of security, the reader is programmed to validate only MIFARE cards whose settings correspond to the Master card that is used to configure the reader. Then, a configuration card is used to configure the following settings:

- Card transfer format
- MIFARE card Key A value
- LED and buzzer control enable
- Lock-out settings
- Transmission of Card Serial Number (CSN) or card ID from dedicated sector



The configuration card is configured using the Desktop Programmer (CP-R26). Refer to the *CP-R26 Hardware and AS-B01 Software Manual* for more details.

4.1 Configuration Procedure

The reader will not work until it is configured upon initial use. It is recommended to configure the reader one time only, following installation and its initial use. However, if needed, configuring the reader can be done anytime using the same procedure described below.

To configure the reader:

1. Present the Master card.

A short beep is generated and the two LEDs begin to blink in orange, as the reader goes into Configuration mode.

2. Within 30 seconds (while the reader is still in Configuration mode), present a valid configuration card to the reader.

If the configuration is valid, 3 short beeps are emitted, and both LEDs flash in green 3 times quickly together.

If the configuration is not valid, an error beep is generated. If the reader is being configured for the first time, the reader will not work until a successful configuration is performed.

If the reader is already in use, then following a failed configuration, the reader returns to Standby mode and continues to work with its previous configuration settings.

5. Testing the Reader

After wiring the reader to the controller and to a power supply, test the reader.

To test the reader:

1. Power up the reader.

Three long beeps are generated and both LEDs flash red simultaneously for 3 seconds.

2. If you have not yet done so, configure the reader as described in Section 4.1.

3. Present the User card to the reader.

If the card is valid, a short confirmation beep is generated and the right LED flashes green indicating a successful read.

4. Following the confirmation, place your finger on the capacitive sensor.

If the fingerprint matches the template on the card, three short confirmation beeps are generated and both LEDs flash green indicating a successful read.

If there is a mismatch, a long and low beep is generated and the right LED flashes green for 10 seconds at which time another attempt to place the finger to attempt matching can be made.

If no finger is presented during the 10 seconds, the reader returns to Standby mode and the left LED lights red.

6. Modes of Operation

The AY-Bx660 readers have the following modes of operation:

- Boot Mode (reset)
- Configuration Mode
- Standby Mode
- Read Mode
- Lockout Mode
- Fingerprint Matching Override Mode
- Duress Mode

6.1 Boot Mode

The reader enters Boot mode upon power up or upon restoration of power after a power failure where the loader runs separately from the main application. The Boot mode lasts for approximately three seconds, during which the red LEDs flash simultaneously.

6.2 Configuration Mode

Refer to Section 4.1 on how set the reader to Configuration mode.



The configuration card is configured using the Desktop Reader (CP-R26) and the card programmer and fingerprint enrollment. Refer to the *CP-R26 Hardware and AS-B01 Software Manual* for more details.

6.3 Standby Mode

The reader enters Standby mode:

- After the Boot (reset) and Configuration modes
- After the Lockout mode period
- After a successful card or fingerprint read

During Standby mode, the left red LED remains lit to indicate Standby mode and the reader is ready for normal use.

6.4 Read Mode

The reader enters Read mode when a user presents a MIFARE card and then places a finger on the capacitive sensor. The card and/or fingerprint can have a valid or invalid value and/or match.

Following a correct card read the right green LED blinks indicating the user to place his finger on the reader.

6.4.1 Valid Card/Fingerprint Read

When card and fingerprint reads are valid, the following sequence occurs:

1. While the reader is in Standby mode, a user presents a MIFARE card to the reader.
2. A short beep is generated and the right LED flashes green, indicating that the reader is waiting for the finger to be placed.
3. Place your finger onto the fingerprint reader.

When a match is found, three short beeps are generated, and the two LEDs flash green indicating a success.



If the user does not place a finger within 10 seconds, the reader returns to Standby mode and the user must restart the identification procedure.

4. The data is transmitted to the access controller, according to the reader's configured transmission format. The reader then re-enters Standby mode.

6.4.2 Invalid Card/Fingerprint Read

An invalid card or fingerprint read can occur when:

- The card is not verified.
- There is an error in fingerprint presentation (for example, the user places the finger incorrectly).
- There is a mismatch between the fingerprint and the template (for example, the user presents the wrong finger).

When a card or fingerprint read is invalid, the following sequence occurs:

1. A user presents a MIFARE card to the reader. This can occur during Standby mode (at the beginning of the identification procedure), or following a successful read of the first means of identification.
2. If the card or fingerprint is wrong, the two LEDs turn red and the buzzer emits a long, low, invalid indication beep is generated. After this, the user can re-attempt to present the card or finger.
3. Based on the Lockout mode configuration, explained ahead, several invalid reads within 30 seconds initiates the lockout mode.

If there are fewer than the pre-configured number of invalid card/fingerprint reads within 30 seconds, the reader enters Standby mode.



When connected and operating with Rosslare's controllers and the AxTrax software, the readers send specific messages when failures occur. Those messages appear and can be handled on the AxTrax software:

- Fingerprint data reading from card failed
- Swipe sensor Fingerprint reading failed
- Fingerprint swipe sensor/card verification failed

6.5 Lockout Mode

The reader enters Lockout mode when there are a number of invalid card and/or finger reads within a 30-second period. During Lockout mode, the two LEDs flash red simultaneously for one minute. After one minute, the reader enters Standby mode.



The default number of invalid reads before the reader enters Lockout mode is 5. The number of invalid reads can be programmed to be 1 to 10.

The default duration of Lockout mode is one minute. The duration can be programmed to be 1–5 minutes.

6.6 Fingerprint Matching Override Mode

It is possible to configure specific user cards to ignore fingerprint matching for people that may have trouble with fingerprint readings. This configuration is done during the enrollment process using the CP-R26 programmer and AS-B01 software. If Override mode is enabled, the user needs only to place a finger on the sensor and the reader sends the user's ID without matching a fingerprint template.

6.7 Duress Mode

The system allows the user to send a duress message when placing the finger on the reader. The duress signal is then sent to the panel and appears as an alert in the access control management software.

The duress mode is defined on the user ID card itself during configuration using the CP-R26 programmer and AS-B01 software. If Duress mode is enabled, one finger template is used in normal access, and the other is defined as a duress signal. The user then places the second finger configured and the reader automatically sends the user's ID to the panel along with a duress message.

A. Limited Warranty

The full ROSSLARE Limited Warranty Statement is available in the Quick Links section on the ROSSLARE website at www.rosslaresecurity.com.

Rosslare considers any use of this product as agreement to the Warranty Terms even if you do not review them.



Asia Pacific, Middle East, Africa

Rosslare Enterprises Ltd.

Kowloon Bay, Hong Kong

Tel: +852 2795-5630

Fax: +852 2795-1508

support.apac@rosslaresecurity.com

United States and Canada

Rosslare Security Products, Inc.

Southlake, TX, USA

Toll Free: +1-866-632-1101

Local: +1-817-305-0006

Fax: +1-817-305-0069

support.na@rosslaresecurity.com

Europe

Rosslare Israel Ltd.

Rosh HaAyin, Israel

Tel: +972 3 938-6838

Fax: +972 3 938-6830

support.eu@rosslaresecurity.com

Latin America

Rosslare Latin America

Buenos Aires, Argentina

Tel: +54-11-4001-3104

support.la@rosslaresecurity.com

China

Rosslare Electronics (Shenzhen) Ltd.

Shenzhen, China

Tel: +86 755 8610 6842

Fax: +86 755 8610 6101

support.cn@rosslaresecurity.com

India

Rosslare Electronics India Pvt Ltd.

Tel/Fax: +91 20 40147830

Mobile: +91 9975768824

sales.in@rosslaresecurity.com

ROSSLARE
SECURITY PRODUCTS
www.rosslaresecurity.com

